

INTREX SET 1201 & 1501 LABELLING SYSTEM

HIGHLY FLEXIBLE MACHINES FOR SIDE OR TOP PRODUCT LABELLING

- Designed to apply labels on regular, dimensionally stable product such as boxes, multipacks, etc.
- Capacity up to 100 products per minute
- May be used as standalone units, or integrated into the production line
- The machines can be supplied with a variety of conveyor belt dimensions, customized to suit customer's product or line requirements
- Adjustable side rails allowing for precise product guidance
- Rigid and compact design
- Machine based on one rigid stainless steel frame equipped with castors

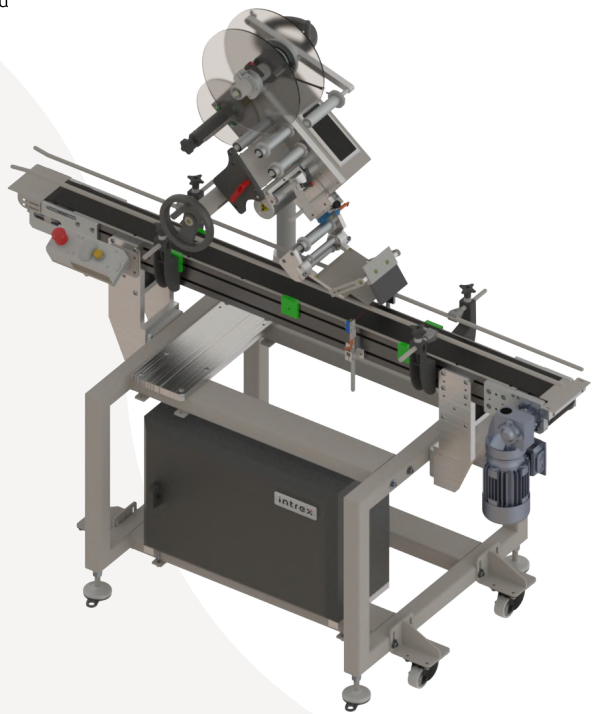

INTREX SET 1501

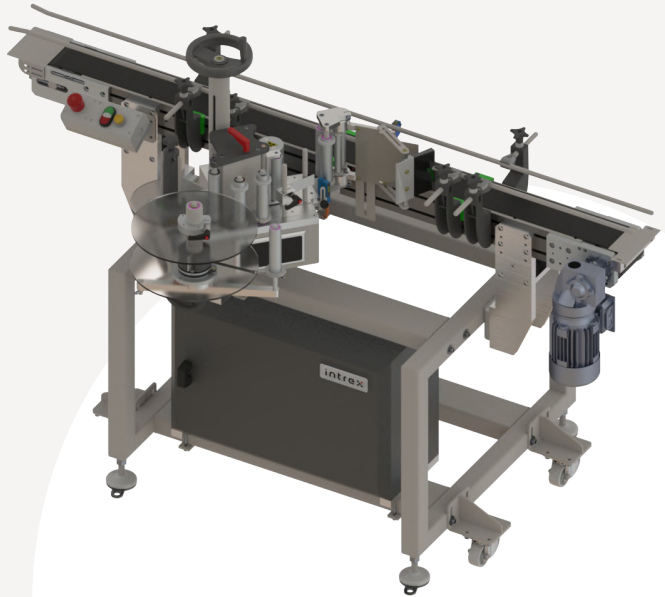

INTREX SET 1201



The real maximum labelling speed depends on the label, capacity, type of the labelled product and the kind of application.
The label feeding precision depends on the label and the labelled product properties.



PARAMETERS

INTREX SET 1201 & 1501

LABELLING HEAD	INTREX 100+ (optional: INTREX 200+)
MAX LABEL WIDTH	90 mm, 160 mm (optional: 220 mm)
MAX LABEL ROLL DIAMETER (UNWINDER)	300 mm (may be increased to 350 mm), 40 mm or 76 mm core diameter
LABEL SENSOR	Optical (optional ultrasonic sensor for transparent labels)
MAX CAPACITY	Up to 100 products per minute
INTREX SMART PANEL	Simplified, 2-line LCD panel with buttons, integrated into labelling heads. Up to 16 labelling programs memory.
CONVEYOR	100 mm wide belt, 1500 mm long (accordingly to product dimensions)
POWER SUPPLY	230 VAC, 50 Hz

INTREX SET 1501

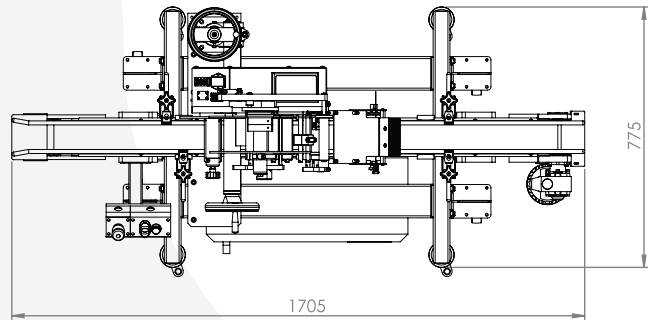
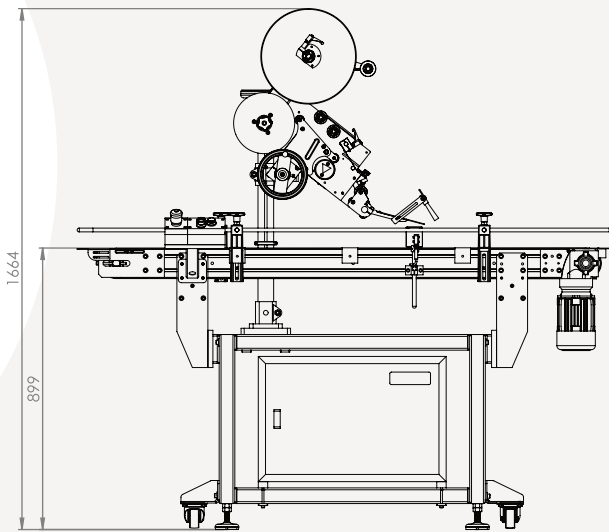

INTREX SET 1201

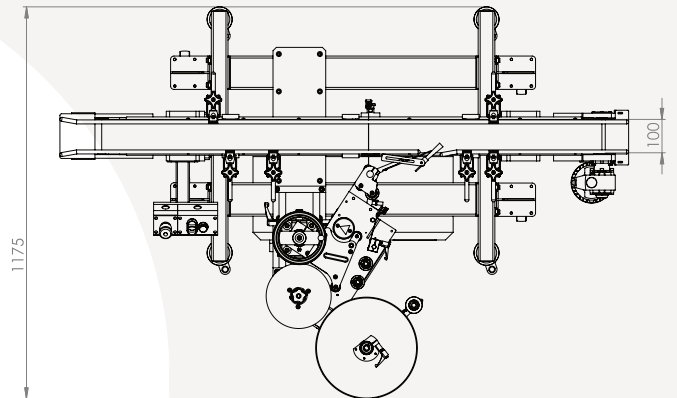
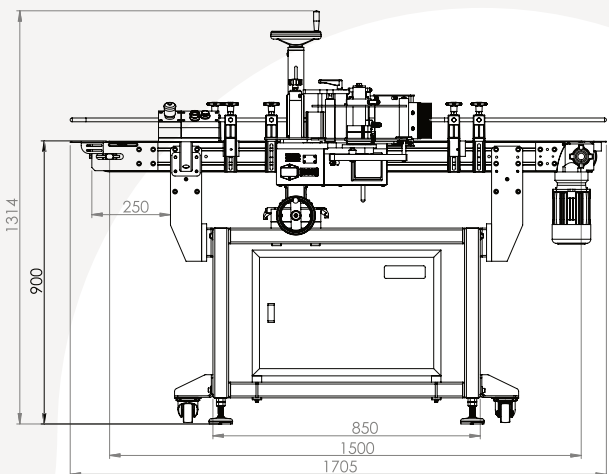

The real maximum labelling speed depends on the label, capacity, type of the labelled product and the kind of application.
The label feeding precision depends on the label and the labelled product properties.

