

INTREX SET 1232F LABELLING SYSTEM

"TAMPER-EVIDENT" LABELLING SYSTEM

- Solution for tamper-evident labelling of carton boxes
- Simple changeover between products
- Wide range of labelled product sizes
- Possibility to apply labels on the same or opposite sides of the product
- Capacity of up to 250 pieces per minute
- High precision of label application
- Verification of correct label application on the product
- Intrex SMART Panel - intuitive control panel. Allows operation of all machine functions and the entire labelling process in one place
- Construction made of stainless steel

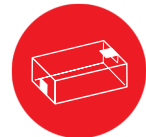

The real maximum labelling speed depends on the label, capacity, type of the labelled product and the kind of application.
The label feeding precision depends on the label and the labelled product properties.

PARAMETERS

INTREX SET 1232F

LABELLING HEAD	INTREX 50+ 90 200
MAX LABEL ROLL WIDTH	90mm
MAX LABEL ROLL OUTER DIAMETER	200mm
LABEL SENSOR	Optical (option: ultrasonic for transparent labels)
MAX CAPACITY	250 products per minute
CONTROL	Intrex SMART Panel - intuitive user graphic interface
POWER SUPPLY	230 VAC, 50 Hz

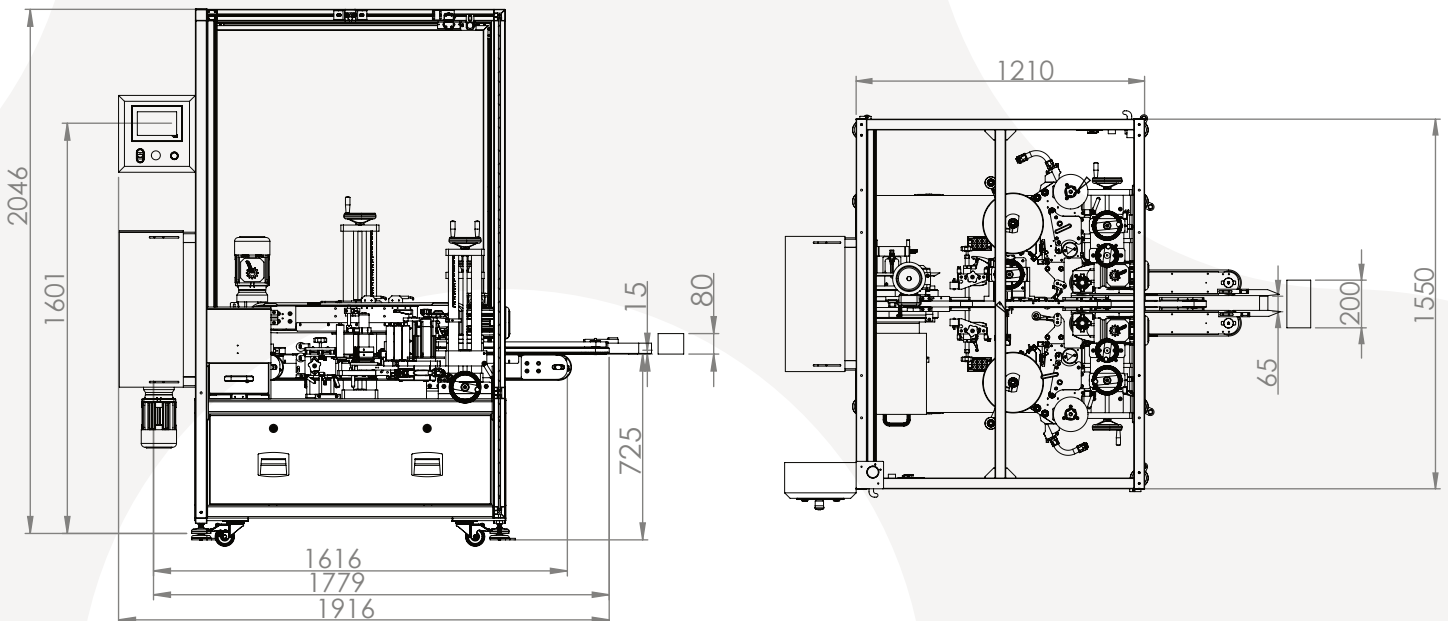

The real maximum labelling speed depends on the label, capacity, type of the labelled product and the kind of application.
The label feeding precision depends on the label and the labelled product properties.