

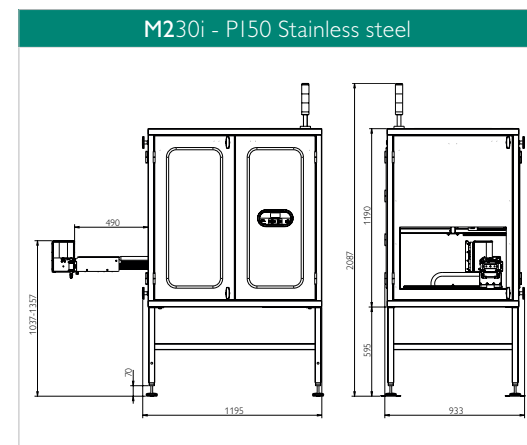

Technical Specification M230i Pallet Labeller

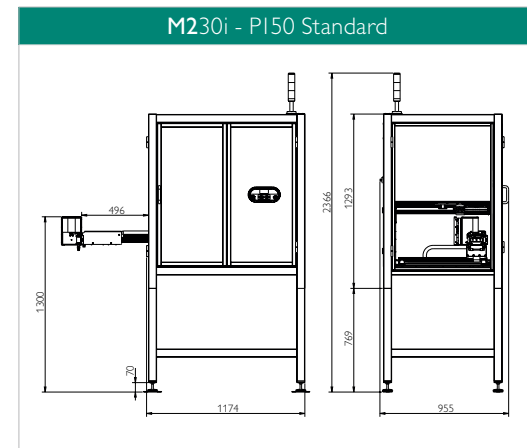

Models	M230i - P150 Standard	M230i - P150 Stainless steel
Enclosure	Aluminium cabinet	Stainless steel cabinet
Left or Right handed version	●	●
Tamp applicator, with blow	●	●
Number of labels per product	1, 2 or 3 (3 sides as optional)	1, 2 or 3 (3 sides as optional)
Possible label positions	Front, Side or Back	Front, Side or Back
	Front and Side	Front and Side
	Back and Side	Back and Side
Label widths allowed	60 to 150 mm	60 to 150 mm
	Label lengths allowed	40 to 210 mm
Max distance to product (To comply with GS1 standards)	450 mm	450 mm
Cycle time	18 seconds (2 labels on 2 adjacent sides)	20 seconds (2 labels on 2 adjacent sides)
	13 seconds (1 label on back or front)	15 seconds (1 label on back or front)
	5 seconds (1 label on side)	7 seconds (1 label on side)
Thermal Transfer capability	●	●
Direct Thermal capability	●	●
12 dots/mm (300dpi) print resolution	●	●
Max print width	162 mm	162 mm
Max width of backing paper	168 mm	168 mm
Max ribbon width	170 mm	170 mm
Max ribbon roll length	600 m	600 m
Ribbon rolled	ink-out	ink-out
Max label roll outer diameter	340 mm	340 mm
Label roll inner diameter	76 mm	76 mm
Minimum label gap	3 mm	3 mm
Input air pressure	6 bar - clean dry air	6 bar - clean dry air
Air consumption (per cycle)	24 Litres (2 labels on 2 adjacent sides)	26 Litres (2 labels on 2 adjacent sides)
	15 Litres (1 label on back or front)	17 Litres (1 label on back or front)
	9 Litres (1 label on side)	11 Litres (1 label on side)
Power consumption (per cycle)	1310 Ws (2 labels on 2 adjacent sides)	1310 Ws (2 labels on 2 adjacent sides)
	670 Ws (1 label on back or front)	670 Ws (1 label on back or front)
	470 Ws (1 label on side)	470 Ws (1 label on side)
Idle power	60 W	60 W
Status beacon (Green/Yellow/Red)	●	●
Extra home position sensor	●	●
Low level media sensors	●	●
Machine stop	●	●
Sensor guarding on all doors	●	●
Adjustable feet on cabinet (+/- 50 mm)	●	●
Non-stick pad	●	●
Check scanner	Optional	Optional
Automatic front door	Optional	●
Label check	Optional	Optional
Touchpanel	Optional	Optional
AC	Optional	Optional
Heater	Optional	Optional
3-sided	Optional	Optional
Communication interface	Ethernet, RS232	Ethernet, RS232
I/Os	10 configurable inputs	10 configurable inputs
	1 fixed + 10 configurable outputs	1 fixed + 10 configurable outputs
Input voltage	90-250VAC 50-60Hz	90-250VAC 50-60Hz
Operating temperature	5°C to 40°C	5°C to 40°C
Weight	185 Kg	225 Kg
CE approved	●	●

● = Standard features

M230i Pallet Labeller

Exceeding expectations for reliability and performance



The M230i Pallet Labeller is a flexible and reliable automated pallet labelling solution to deliver unparalleled performance for many years to come.

Domino Systems A/S
 Marielundvej 46A & 46C
 2730 Herlev
 T: +45 47 10 73 00
 M: kontakt@dominosystems.dk

www.dominosystems.dk

We reserve the right to change the design or specification of our products without notice. Some of the information contained in this brochure is general in nature and customers should check that it is applicable to their individual circumstances.

M230i Pallet Labeller0414

All performance-related figures and claims quoted in this document were obtained under specific conditions and may only be replicated under similar conditions. For specific product details, you should contact your Domino Sales Advisor. This document does not form part of any terms and conditions between you and Domino.

Domino. Do more.

Offering the last word in reliability and performance the M230i Pallet Labeller will give you a cost effective and flexible solution to your pallet labelling requirements.

The M230i Pallet Labeller series offers a wide range of standard features built into cabinets of either stainless steel or aluminium. It delivers a flexible, reliable, safe, and easy-to-operate solution to ensure maximum productivity for many years to come, even in the harshest of industrial environments. In short, it's a labelling solution made on your terms.

Rugged industrial design

The M230i Pallet Labeller is compact in size, yet rugged and industrialised. Thanks to its innovative design the applicator can easily be set up to label one, two, or three sides of the pallet, giving you the flexibility to meet both current and future requirements.

Simple integration

Ease of integration is key for our customers and the clean, modular design of the M230i Pallet Labeller ensures this, whether you are installing a brand new facility or integrating automated pallet labelling into an existing line. Our suite of powerful software packages helps facilitate this, and we offer full support during the design and implementation phases of the project.

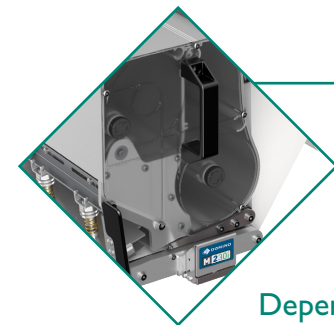

Dependable reliability

The M230i's innovative design and robust construction ensures that labels are applied with perfect precision for years to come. An optional integrated check scanner ensures that pallets cannot move on until they have fully readable barcode labels applied.

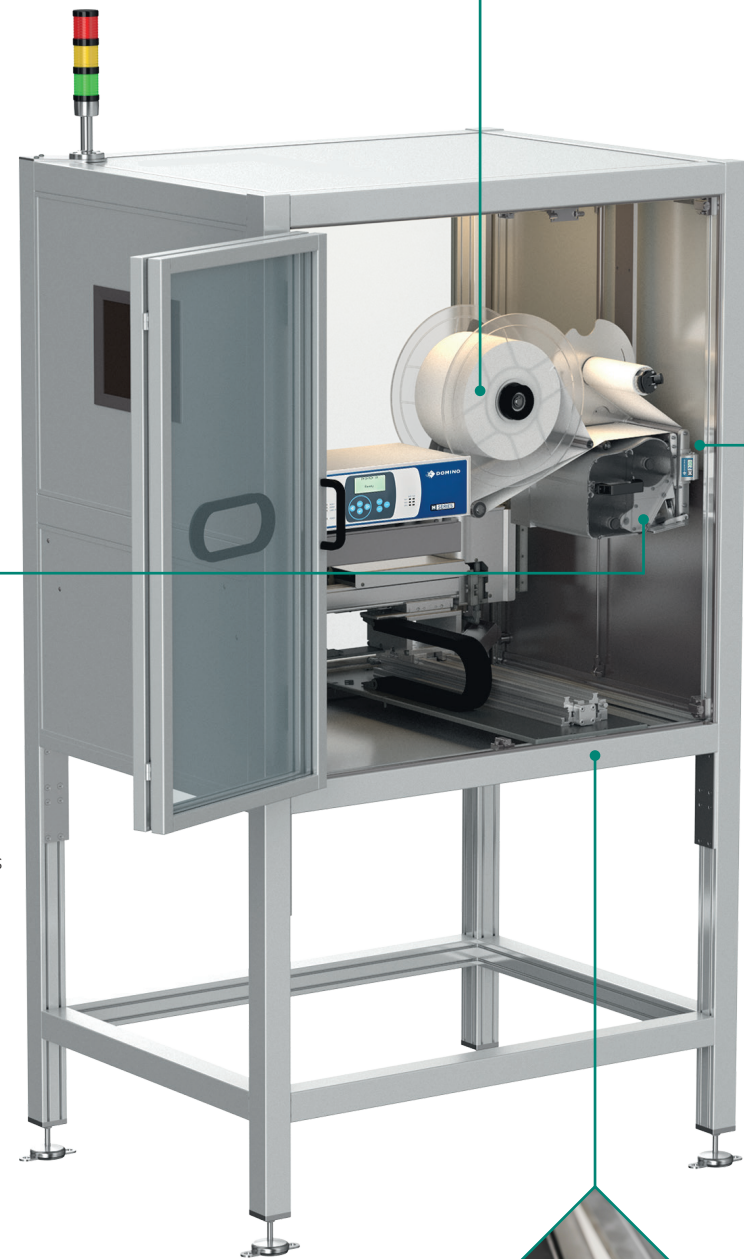

Safe operation

Cabinet mounted sensors prevent operator access to moving parts, ensuring safe yet convenient operation.

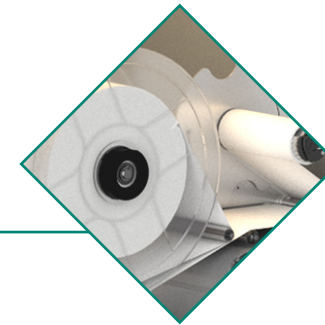

Ease of use

Protected quick-release connectors for secure and easy installation. Simple label & ribbon paths, with clear colour threading diagrams. RS232 & Ethernet interfaces and multiple configurable I/O's make integration easy.

Flexibility

Unique applicator head design allows easy configuration for every application. The innovative non-stick applicator pad easily handles standard label sizes, e.g. A5 and A6.

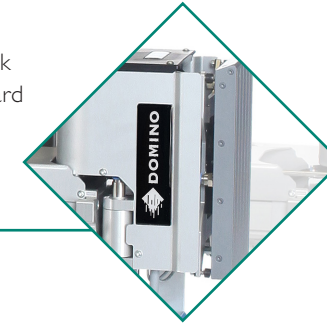

Supply Chain Traceability

Pallet labelling is the foundation of supply chain traceability, creating a unique identity that is essential for shipments, warehousing, and storage of goods. The M230i Pallet Labeller offers the traceability customers have come to rely on.

Built to last

All industries have unique requirements and the M230i Pallet Labeller is designed to withstand the challenges. For demanding industries, such as Food & Beverage, the stainless steel cabinet is the preferred choice for maximum protection and durability.

GSI Compliant

The M230i Pallet Labeller allows you to meet the GSI standards by producing fully compliant Serial Shipping Container Code (SSCC) barcode labels. It can be configured to apply labels onto one, two or three sides of the pallet.

Part pallet functionality

Built-in functionality enables the M230i Pallet Labeller to be automatically put into part pallet mode, which ensures safe and easy labelling of part pallets using Domino's popular **QuickDesign** software. Alternatively, an additional desktop printer can be specified and integrated into the system to meet this requirement, while also acting as a back-up printer to the main pallet labeller.



Choice of cabinets

While the ruggedness of the M230i Pallet Labeller's stainless steel cabinet suits the stringent requirements in a variety of industries, for less demanding environments the aluminium cabinet is the most cost efficient solution. It offers the same standard features, such as right and left handed versions, along with spring loaded pad suspension.

The M230i Pallet Labeller offers a wide variety of options, including:

- Air conditioning
- Heater
- Touch screen user interface
- 3-sided labelling

The M230i Pallet Labeller series is designed to give you a labelling machine that will not only stand the test of time, but which also offers unmatched flexibility.

- Quick & easy integration
- Left & right handed versions
- Easy & intuitive communications interface
- Fast & easy service & maintenance